

JBP SERIES

SELF PRIMING JET BOOSTER PUMP

STAINLESS STEEL BODY



AQUATROL™
JET BOOSTER PUMPS

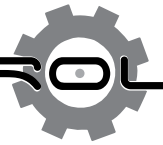

USER'S MANUAL

Table Of Contents

Performance & Warranty	2
Safety Instructions	3
Pre-Installation	4
Installation	6
Discharge Pipe and Pressure Tank Connections	10
Pressure Switch Assembly Instructions	11
Priming	12
Troubleshooting	13
Terms and Conditions	14

Performance

Part #	HP	GPM @ Total Discharge Pressure of 40 psi						Maximum Pressure
		0 ft	5 ft	10 ft	15 ft	20 ft	25 ft	
AQT-JBP12	0.5	10.6	10.3	10.04	9.77	9.51	9.25	50.8 psi (3.5 bar)
AQT-JBP34	0.75	12.1	12.02	11.62	11.36	11.23	10.96	58.0 psi (4 bar)
AQT-JBP10	1.0	13.2	13	12.81	12.55	12.42	12.15	65.3 psi (4.5 bar)
AQT-JBP15	1.5	15.8	15.59	15.19	14.79	14.45	14.13	69.6 psi (4.8 bar)

Warranty

The manufacturer warrants the products to be free from defects in materials and workmanship for a period of one year from date of purchase. This warranty applies only to the original consumer purchaser and only to products used in normal use and service. If within one year this product is found upon examination by the manufacturer to be defective in materials or workmanship, the manufacturer's only obligation, and your exclusive remedy, is the repair or replacement of the product at the manufacturer's discretion, provided that the product has not been damaged through misuse, abuse, accident, modifications, alterations, neglect or mishandling. Your original receipt of purchase is required to determine warranty eligibility.

The purchaser must pay all labor and shipping charges necessary to replace the product covered by this warranty.

This Limited Warranty does not cover products which have been damaged as a result of an accident, misuse, abuse, negligence, alteration, improper installation or maintenance, or failure to operate in accordance with the instructions supplied with the products, or operational failures caused by corrosion, rust, or other foreign materials in the system.

Requests for service under this warranty shall be made by returning the defective product to the manufacturer as soon as possible after the discovery of any alleged defect. The manufacturer will subsequently take corrective action as promptly as reasonably possible.

The manufacturer does not warrant and especially disclaims any warranty, whether express or implied, of fitness for a particular purpose, other than the warranty contained herein. This is the exclusive remedy and any liability for any and all indirect or consequential damages or expenses whatsoever is excluded.

Some states do not allow the exclusion or limitation of incidental or consequential damages or limitations on how long an implied warranty lasts, so the above limitations or exclusions may not apply to you. This warranty gives you specific legal rights and you may also have other rights which vary from state to state.

THE FOLLOWING ARE VERY SERIOUS SAFETY ALERTS. MUST OBEY ALL TO REDUCE THE RISK OF PERSONAL INJURY AS WELL AS PROPERTY DAMAGE. PLEASE READ THIS MANUAL IN ITS ENTIRETY AND FOLLOW ALL THE INSTRUCTIONS BEFORE INSTALLATION AND OPERATION.

 **WARNING!** Failure to follow the instructions and warnings in the manual may result in serious or fatal injury and/or property damage, and will void the product warranty. This product must be installed by a qualified professional.

 **DANGER!** Do not pump flammable or explosive liquids such as oil, gasoline, kerosene, ethanol, etc. Do not use in the presence of flammable or explosive vapors. Using this pump with or near flammable liquids can cause an explosion or fire, resulting in property damage, serious personal injury, and/or death.

 **DANGER!** Do not touch the motor housing during operation. The motor is designed to operate at high temperatures. Do not disassemble the motor housing.

 **WARNING!** Wear safety goggles at all times when working with pumps.

 **CAUTION!** Secure the pump to a solid base.

 **WARNING!** ATTEMPTING TO USE A DAMAGED PUMP can result in property damage, serious personal injury, and/or death.

 **DANGER!** ALWAYS disconnect the power to the pump before servicing.

 **DANGER!** Do not handle the pump or pump motor with wet hands or when standing on a wet or damp surface, or in water.

 **WARNING!** Protect the electrical cord from sharp objects, hot surfaces, oil, and chemicals. Avoid kinking the cord. Do not use damaged or worn cords.

 **IMPORTANT!** Ensure the electrical power source is adequate for the requirements of the pump.

 **WARNING!** This is a dual voltage 110/220V pump. VOLTAGE SELECTOR INSIDE PRESET TO 220V.

For 220V selection, please open the terminal cover and switch plates to the proper voltage. All wiring should be performed by a qualified electrician.

 **CAUTION!** Follow all local electrical and safety codes, along with the National Electrical Code (NEC).

In addition, all Occupational Safety and Health Administration (OSHA) guidelines must be followed.

 **WARNING!** The pump should be connected to a 110/220V, GFCI outlet protected with a 10 amp 220V/20 amp (110V) fuse or circuit breaker.

 **CAUTION!** Periodically inspect the pump and system components. Disconnect the pump from the power supply before inspecting.

 **CAUTION!** Know the pump and its applications, limitations, and potential hazards.

 **IMPORTANT!** The motor of this pump has a thermal protector that will trip if the motor becomes too hot.

The protector will reset itself once the motor cools down and an acceptable temperature has been reached. The pump may start unexpectedly if it is plugged in.

 **IMPORTANT!** This pump is made of high-strength, corrosion resistant materials. It will provide trouble-free service for a long time when properly installed, maintained, and used.

However, inadequate electrical power to the pump, dirt, or debris may cause the pump to fail. Please carefully read the manual and follow the instructions regarding common pump problem and remedies.



Part Numbers	Power Supply		Liquid Temp. Range	Discharge Size	Maximum Suction Head
AQT-JBP12					
AQT-JBP34	110V/60Hz (12.2 Amps)	220V/60Hz (6.1 Amps)	32 °F - 113 °F (0 °C - 40 °C)	1" FNPT	29.5 ft (9m)
AQT-JBP10					
AQT-JBP15					



WARNING! All joints and connections must be AIRTIGHT. A single leak will prevent the proper operation of the pump. Wrap thread tape clockwise on all threaded connections. For all non-threaded connections, you must use PVC Purple Primer and PVC Cement to ensure airtight seals. Measure all pipe lengths before attaching.



NOTE: A foot valve is a check valve that is used to keep the water from running back into the well from the pump and maintain hydraulic pressure when the pump is not running. If the foot valve does not hold the water the pump will lose its prime and will not pump water. If the foot valve open pressure is too high (the spring is too stiff), or the flow area is too small, the pump suction head and flow rate will significantly drop.

APPLICATION

This unit is a single stage jet pump designed for shallow water well applications, where the water level is less than 29.5 ft. deep.

If the water level to the pump is deeper than 29.5 ft., a convertible jet pump or a deep well submersible pump should be used.

A pressure switch pre-set at 30 psi "on", 50 psi "off" should be installed on the pump. The pressure switch will automatically turn the pump on and off based on the system pressure.

DETERMINE THE DEPTH OF YOUR WELL

Tie a small but heavy weight such as a fishing weight to the end of a piece of cotton string (Figure 1).

Lower the weight into the well until it reaches the bottom of the well. Make a mark on the string at ground level.

Pull the weight out of the well and measure from the bottom of the weight to the ground level mark. This is the depth of your well. Subtract 5 ft. from the depth of your well. If this number is less than 25 ft., shallow well installation should be taken. If this number is more than 25 ft. and less than 70 ft., deep well installation should be taken. If this number is more than 70 ft., a deep well submersible pump should be selected.

Measure the ground level mark to the mark where the cotton string is wetted. This number is your well's water level. It should also be at least 10 ft. below the well's water level while the pump is running in order to prevent the pump from sucking air due to water level drawdown.

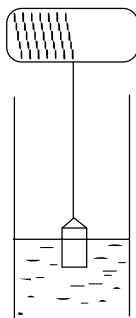

Figure. 1

LOCATION OF THE PUMP

Decide on the area for the pump installation. Select a pump location with adequate space for future pump maintenance. It can be located in the basement or utility room of the house, at the well, or between the house and the well.

If installed outside of the house, it should be protected by a pump house with auxiliary heat to prevent possible freezing.

Protect the pump against flooding and excess moisture. The well also should be protected for sanitary reasons. Mount the pump as close to the well as possible.

TANKS - PRE-CHARGED STORAGE

For best performance of the pump, it is recommended that you use a diaphragm pressure tank (sold separately). It is best to have this in place before installing the pump.

A pre-charged storage tank has a flexible bladder or diaphragm that acts as a barrier between the compressed air and water. This barrier prevents the air from being absorbed into the water and allows the water to be acted on by compressed air at initially higher than atmospheric pressures (pre-charged). More usable water is provided than with a conventional type tank.

The pump should be equipped with a 30/50 psi pressure switch, which means the "cut-in" is 30 psi; therefore, the tank needs to be set to 28 psi. To check the pressure in the tank, use a tire pressure gauge (not included).

If the tank pre-charged less than 28 psi, re-charge air to the tank to 28 psi with a tire pump or air compressor. If the tank pre-charged over 28 psi, bleed out some air to 28 psi.

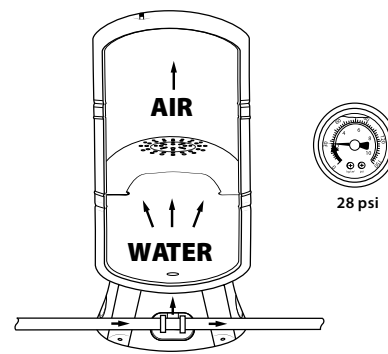



WARNING! ELECTRICAL SAFETY CAPACITOR VOLTAGE MAY BE HAZARDOUS. To discharge the motor capacitor, hold the insulated handle screwdriver **BY THE HANDLE** and short capacitor terminals together. **DO NOT** touch the metal screwdriver blade or capacitor terminals. If in doubt, consult a qualified electrician.



WARNING! The pump body may explode if used as a booster pump unless a relief valve capable of passing full pump flow at 75 psi is installed.



CAUTION! **DO NOT** touch an operating motor. Modern motors are designed to operate at high temperatures. To avoid burns when servicing the pump, allow it to cool for 20 minutes after shut-down before handling.



CAUTION! Do not allow pump or any system component to freeze. To do so will void warranty.



CAUTION! Pump water **ONLY** with this pump.



CAUTION! Periodically inspect the pump and system components.



CAUTION! Wear safety glasses at all times when working on pumps.



CAUTION! Keep the work area clean, uncluttered and properly lighted; store properly all unused tools and equipment.



CAUTION! Keep visitors at a safe distance from the work areas.

SHALLOW WELL JET PUMP INSTALLATIONS

- Have a vertical depth between the pump and the water being pumped of 25 ft. or less. (Figure. 2)
- Have one pipe from the well to the pump case.
- Can be installed in a bored or drilled well, or in a driven well.

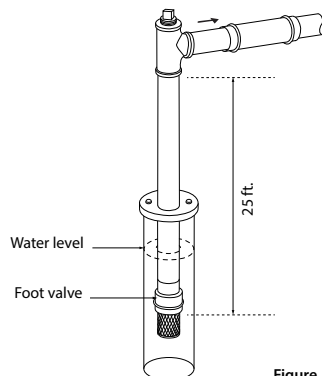

Figure. 2

REPLACING AN OLD PUMP



WARNING! Hazardous voltage. Disconnect power to the pump before working on a pump or a motor.

- Drain and remove the old pump. Check the old pipe for scale, lime, rust, etc., and replace it if necessary.
- Install the pump in the system. Make sure that all pipe joints in the suction pipe are airtight as well as watertight. **If the suction pipe can suck air, the pump will not be able to pull water from the well.**
- Adjust the pump mounting height so that the plumbing connections do not put a strain on the pump body. Support the pipe so that the pump body does not take the weight of piping or fittings.
- You have just completed the well plumbing for your new shallow well jet pump.

WELL POINT (DRIVEN POINT) INSTALLATION

(Figure. 3)

- Drive the well, using drive couplings and a drive cap. Drive fittings are threaded all the way through and allow the pipe ends to butt against each other so that the driving force of the maul is carried by the pipe and not by the threads. The ordinary fittings found in hardware stores are not threaded all the way through the fitting and can collapse under impact. Drive fittings are also smoother than standard plumbing fittings, making ground penetration easier.
- Mount the pump as close to the well as possible. Use the fewest possible fittings (especially elbows) when connecting the pipe from the well point to the pump suction port. The suction pipe should be at least as large as the suction port on the pump (include a check valve as close to the well as possible).
- Support the pipe so that there are no dips or sags in the pipe, so it does not strain the pump body, and so that it slopes slightly upward from the well to the pump (high spots can cause air pockets which can air lock the pump).
- Seal the suction pipe joints with Teflon tape. Joints must be air and watertight. If the suction pipe can suck air, the pump cannot pull water from the well. If one well point does not supply enough water, consider connecting two or three well points to one suction pipe.
- You have just completed the suction piping for your new shallow well jet pump.

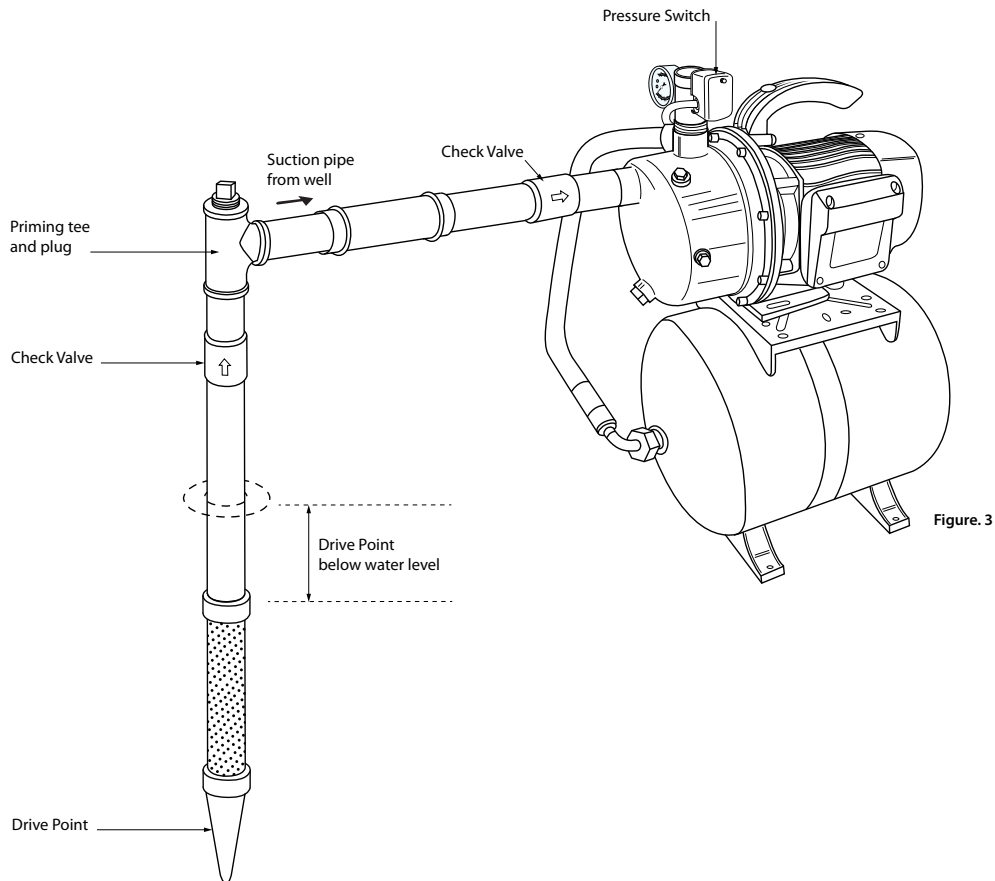

Installation (Continued)

Cased Well Installation



CASED WELL INSTALLATION, 2" OR LARGER CASING

(Figure. 4)

- Mount the pump as close to the well as possible.
- Assemble the foot valve, strainer, and well pipe. Make sure that the foot valve works freely.
- Lower the pipe into the well until the strainer is 5 ft. above the bottom of the well. It should also be at least 10 ft. below the well's water level while the pump is running in order to prevent the pump from sucking air. Install a sanitary well seal.
- Install a priming tee, priming plug, and suction pipe to the pump.
- Connect the pipe from the well to the pump suction port, using the fewest possible fittings – especially elbows – as fittings increase friction in the pipe (however, include a foot valve).
- The suction pipe should be at least as large as the suction port on the pump. Use Teflon tape on threaded pipe joints. Support the pipe so that there are no dips or sags in the pipe, so it does not strain the pump body, and so that it slopes slightly upward from the well to the pump (high spots can cause air pockets which can air lock the pump).
- Seal the suction pipe joints with Teflon tape. Joints must be air-tight and water-tight. If the suction pipe can suck air, the pump cannot pull water from the well.
- You have just completed the suction piping for your new shallow well jet pump.

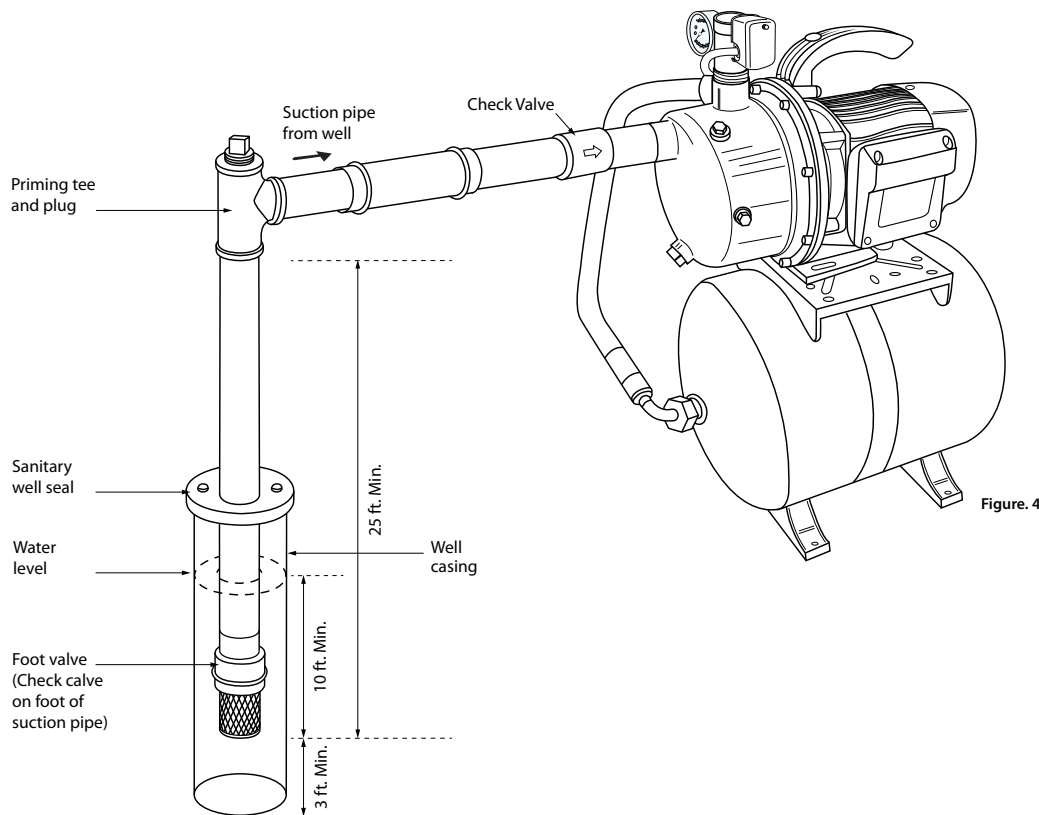

INSTALLATION FOR SURFACE WATER

(Figure. 5)

- The pump should be installed as close to the water as possible, with the fewest possible fittings (especially elbows) in the suction pipe. The suction pipe should be at least as large as the suction port on the pump.
- Assemble a foot valve and suction pipe. Make sure that the foot valve works freely. Use Teflon tape on threaded pipe joints. Protect the foot valve assembly from fish, trash, etc, by installing a screen around it.
- Lower the pipe into the water until the strainer is 5ft. above the bottom. It should also be at least 10ft. below the water level in order to prevent the pump from sucking air.
- Install a priming tee, priming plug, and suction pipe to the pump.
- Support the pipe so that there are no dips or sags in the pipe, so it does not strain the pump body, and so that it slopes slightly upward from the well to the pump (high spots can cause air pockets which can air lock the pump).
- Seal the suction pipe joints with teflon tape.
- Joints must be air-tight and water-tight. If the suction pipe can suck air, the pump cannot pull water from the well.
- You have just completed the plumbing for your new shallow well jet pump.

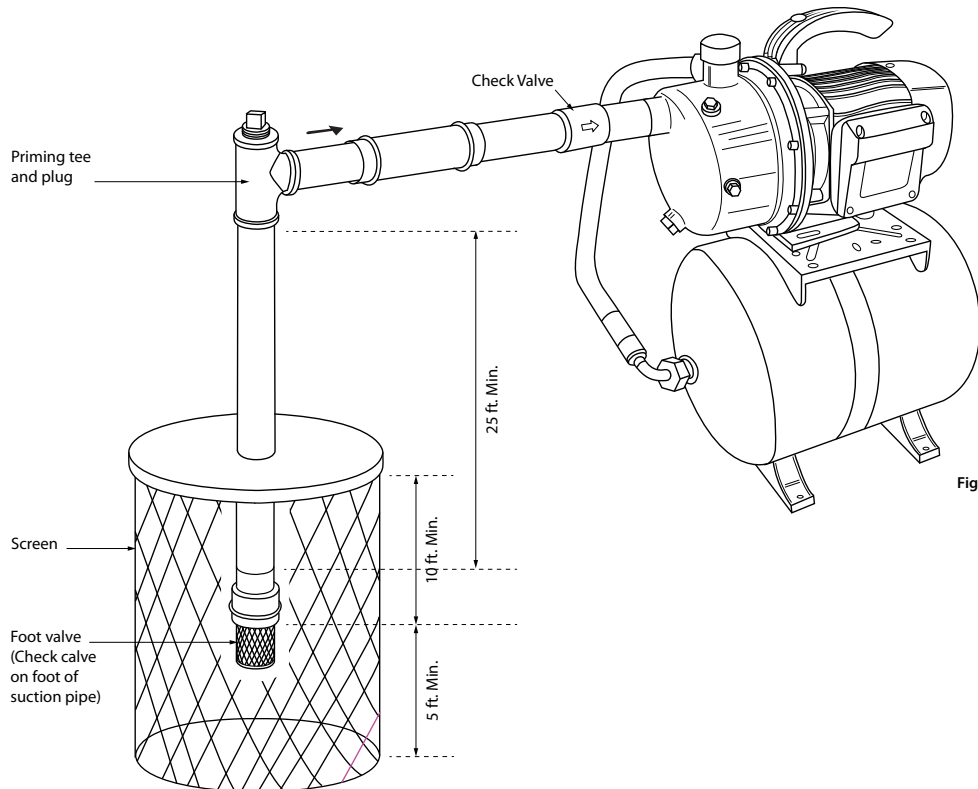

Figure. 5

PRE-CHARGE TANK CONNECTION

- Install two tees in the pump discharge port. The pipe size must be at least as large as the discharge port.



NOTE: A pre-plumbed pump-on-tank system only requires one tee.

- Run a pipe or reinforced hose from one arm of the first tee to the port on the pre-charged tank.
- Connect the other discharge tee to your plumbing system.
- Check the pre-charge of air in the tank with an ordinary tire gauge. Your new pump has a 30/50 psi switch, so adjust the tank pre-charge pressure to 28 psi.
- The pre-charge is measured when there is no water in the tank. The pre-charge should be 2 psi less than the

cut-in setting of the pump's pressure switch. If the tank pre-charged less than 28 psi, re-charge air to the tank to 28 psi with a tire pump or air compressor. If the tank pre-charged over 28 psi, bleed out some air to 28 psi.

- *Congratulations!* You have just completed the tank connection for your jet pump.

(Figure. 6)



NOTE: Sealing Pipe Joints. Use only Teflon tape for making all threaded connections to the pump itself. Do not use pipe joint compounds on plastic: they can react with the plastic. Make sure that all pipe joints in the suction pipe are airtight as well as water tight. If the suction pipe can suck air, the pump will not be able to pull water from the well.

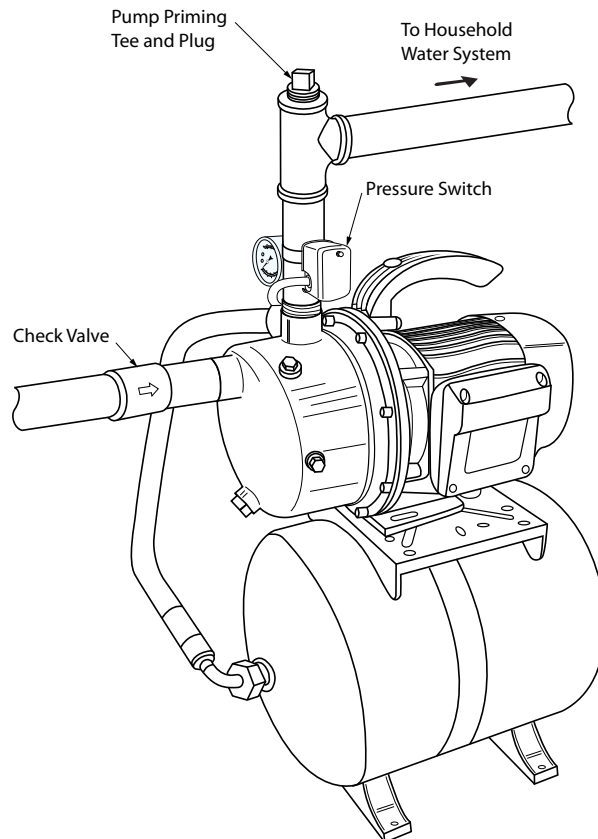

Figure. 6



WARNING! It is recommended all electrical work be performed by a licensed electrician..



WARNING! When wiring from the power source to the pressure switch, it is recommended that you use either a 14-gauge or 12-gauge cord.



CAUTION! Before wiring the pressure switch, turn off the power source to which you are connecting to avoid potentially life threatening electrical shock.

PRESSURE SWITCH

ASSEMBLY INSTRUCTIONS

(Figure. 7)

To complete the installation, you must connect the power source to the pressure switch. A 30/50 PSI pressure switch should be installed on the pump. The pressure switch allows for automatic operation; the pump starts when pressure drops to the “cut-in” setting (30 PSI pre-set).

Wire to pressure switch installation Instructions .

Pressure Switch
Cover

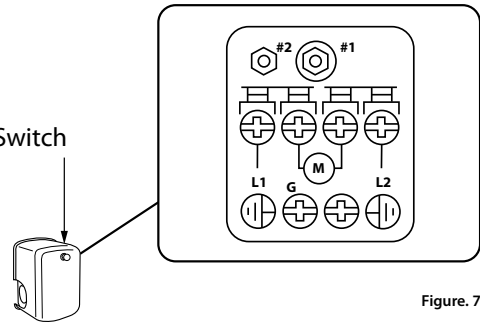

Figure. 7



CAUTION! Do NOT use a pressure switch set at a pressure greater than 50 psi. The pump will not create pressures greater than 50 psi, if so the pump will never shut off, resulting in damage to the pump and voiding the warranty.

VOLTAGE SETTING

(Figure. 8)

- This pump is pre-wired at 110 volts.
- If the power source is 220 volts, remove the electrical housing cover.
- Switch plates according to diagram for 220V.



NOTE: All electrical work should be performed by a licensed electrician.

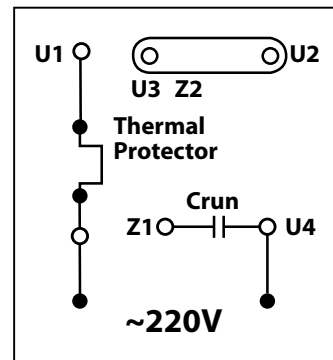

Figure. 8

Priming

Priming & Winterizing the Pump Instructions



WARNING! Never run the pump against a closed discharge. To do so can boil water inside the pump, causing hazardous pressure in the unit, risk of explosion and possibly scalding persons handling the pump.



CAUTION! Fill the pump with water before starting. NEVER RUN THE PUMP DRY. Running the pump without water may cause the pump to overheat, damaging the seal and possibly causing burns to persons handling the pump.

PRIMING INSTRUCTIONS

(Figure. 9)

- Remove the priming plug from the priming tee and fill the pump. Fill all piping between the pump and the well and make sure that all piping in the well is full. If you have also installed a priming tee in the suction piping, remove the plug from the tee and fill the suction piping.
- Replace all fill plugs (use teflon tape).
- Power on! Start the pump. If you do not have water in 2 minutes, stop the pump and remove the fill plugs. Refill the pump and piping. You may have to repeat this several times in order to get all the trapped air out of the piping. A pump lifting water 25 ft. may take as long as 15 minutes to prime.
- After the pump has built up pressure in the system and shut off, check the pressure switch operation by opening a faucet or two and running enough water out to bleed off pressure until the pump starts. The pump should start when pressure drops to 30 PSI and stop when pressure reaches 50 PSI.

- Run the pump through one or two complete cycles to verify correct operation. This will also help clean the system of dirt and scale dislodged during installation.
- *Congratulations* on a successful installation!

WINTERIZING THE PUMP

To prepare the pump for freezing temperatures:

- Shut off power to the pump.
- Relieve system pressure. Open a faucet and let it drain until water stops flowing.
- Drain the pump. Your pump may have a separate drain plug. Remove this plug and let it drain.
- Your pump may only have a plug or connection on the side of the pump. Remove this and let the pump drain. Some water will remain in the pump. Leave the plug out until you are ready to re-prime.

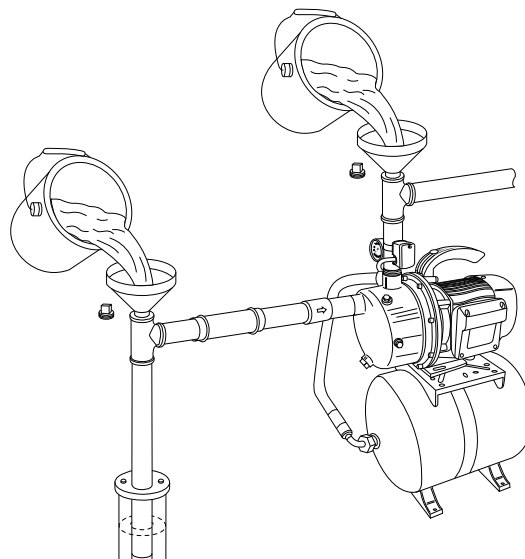

Figure. 9

Problem	Possible Cause	Corrective Action
Pump humming.	1. The motor shaft stuck.	1.1 Please use a flat head screwdriver to turn the motor shaft through the center hole on the motor cap. Then restart the pump.
		1.2 Clean impeller and diffuser.
	2. Selected wrong voltage.	2.1 Pump was pre-set at 230V. Refer to manual for set voltage to 115V.
Does not pump water or low flow.	1. Air in piping or did not prime.	1.1 Stop the motor. Remove the prime plug. Fill the housing pipes with water.
	2. The water level in the well is below the foot valve.	2.1 Lower the suction pipe. If the water level is more than 25 ft., you need a deep well pump.
	3. The foot valve is plugged or leaks.	3.1 Replace the foot valve or dig the well deeper.
	4. Impeller or nozzle blocked by foreign material.	4.1 Clean impeller and nozzle.
Pump does not stop or pressure does not build up.	1. Impeller or nozzle blocked by foreign material.	1.1 Clean impeller and nozzle.
	2. There is a leak in the house piping.	2.1 Locate and repair the leak or reconnect.
The pump starts and stops too often.	1. Pressure in pre-charged tank is not correct.	1.1 Ensure the pressure in the pre-charged tank is set to 2 PSI less than the cut-in pressure.
	2. The pressure switch malfunctioning.	2.1 Replace the pressure switch.
	3. There is a ruptured diaphragm/bladder (pre- charged tank).	3.1 Replace the tank.

TERMS AND CONDITIONS

The products described in this document are hereby offered for sale to be established by Aquatrol, Hydrofit Quick Connect Fittings, Polaris Scientific Ultraviolet, Hydron Membranes, Shok Blok, HydroGuard, HydroScientific, Hydronix Water Technology, any of its subsidiaries and its authorized distributors. This offer and its acceptance by any customer (the "Buyer") shall be governed by all of the following Terms and Conditions. Buyer's order for any item described in this document, when communicated to Aquatrol, Hydrofit Quick Connect Fittings, Polaris Scientific Ultraviolet, Hydron Membranes, Shok Blok, HydroGuard, HydroScientific, Hydronix Water Technology, its subsidiaries or an authorized distributor (the "Seller") verbally or in writing, shall constitute acceptance of this offer. Provided, however, that these terms and conditions shall not operate as a rejection of the Buyer's offer unless such offer contains variances in the description, quantity, price, or delivery schedule of the items.

1. Terms and Conditions of Sale.

All descriptions, quotations, proposals, offers, acknowledgments, acceptances and sales of the Seller's products are subject to and shall be governed exclusively by the terms and conditions stated herein (the "Agreement"). The Buyer's acceptance of any offer to sell is limited to the terms and conditions in the Agreement. Any terms or conditions in addition to or inconsistent with those stated in the Agreement, proposed by the Buyer in any acceptance of an offer by the Seller, are hereby rejected. No such additional, different or inconsistent terms and conditions shall become part of the agreement between the Buyer and the Seller unless expressly accepted in writing by the Seller. The Seller's acceptance of any offer to purchase by the Buyer is expressly conditioned upon the Buyer's assent to all the terms and conditions in this Agreement, irrespective of any terms in addition to, or inconsistent with those contained in the Buyer's offer. Acceptance of the Seller's products shall in all events constitute such assent.

2. Documents.

Unless provided otherwise in the Agreement, all catalog descriptions, illustrations, drawings and literature or independently submitted estimates of performance, weights and measurements or other specifications provided by the Seller are mere approximations and the Seller reserves the right to alter or amend them at any time. The Seller reserves the right to correct clerical or technical errors in the contract documents. The Buyer shall furnish with his order all necessary specifications and information. The Seller takes no responsibility for goods manufactured, priced or delivered not in accordance with the order or the specifications unless the Buyer's order and specifications are clear and correct.

3. Prices.

Unless otherwise provided, all prices contained in our quotations and written acceptances are ex-works and do not include the cost of packing. All orders are accepted on the condition that all such prices are subject to revision by the Seller at any time before the goods are dispatched to take account of any price change. In the event that the Buyer does not place the entire order quoted by the Seller for the Buyer, the Seller reserves the right to revise its prices. The Seller also reserves the right to revise its prices if the Buyer modifies the specification or quantity of the goods or the delivery requirements after the order has been accepted by the Seller.

4. Advice.

All advice given in connection with the Seller's goods is provided without charge to the Buyer. ANY ADVICE AND ASSISTANCE GIVEN BY THE SELLER TO THE BUYER IS GIVEN AT THE BUYER'S RISK, AND THE SELLER SHALL NOT BE LIABLE FOR ANY LOSS, DAMAGE OR CLAIM ARISING THEREFROM.

5. Payment.

(a) Unless otherwise provided in the Agreement, or explicitly agreed upon in writing by the Seller, payment is due in full 30 days from date of shipment of the items purchased herein under. (b) In the case of an installment contract, deliveries or parts, payment for each installment delivery or part shall be made under sub-clause (a) as if the same constituted a separate agreement. (c) Amounts not timely paid shall bear interest at the rate of 2-1/2% above the Seller's bank's prime rate from time to time in force. (d) In the event that the Buyer fails within one calendar month of the date for payment to effect any payment which may be due under the Agreement or any agreement with the Seller, or if the Buyer commits any breach of the Agreement, or if the Buyer becomes insolvent or commits any act of bankruptcy or contemplation of liquidation, the Seller will be entitled, without prejudice to the Seller's other rights, to terminate the Agreement or any unfulfilled part thereof, or at the Seller's option to make partial deliveries.

6. Modifications and Cancellations.

This Agreement is not subject to oral modification or cancellation. A Buyer's request for modification or cancellation will not be incorporated into the Agreement unless the request is accepted by the Seller in a writing that amends the Agreement. Acceptance of any such requested modification or cancellation shall be at the Seller's discretion and shall be upon such terms and conditions as the Seller may require.

7. Handling Charge.

Goods supplied in accordance with the Buyer's order may later be returned to the Seller at the Seller's discretion provided the return is pre-authorized in writing, and the merchandise is unused, in original packages, unaltered, clean and no older than 60 days from the date of shipment by the Seller. The Buyer will be required to pay to the Seller a handling charge of 25% of the purchase price of the returned goods. A copy of the original invoice for the merchandise must accompany all returns.

8. Delivery.

(a) Any delivery dates quoted are approximate only and the Seller shall have no liability for any delays in delivery. (b) Unless provided otherwise, delivery of the goods shall be made when the Seller has notified the Buyer that the goods are ready for dispatch. Regardless of the method of delivery, delivery shall be made F.O.B. Seller's plant, where the risk of loss shall thereupon pass to the Buyer upon the Seller's delivery to a carrier. Notwithstanding that the Seller's prices are ex-works, the Seller is prepared by special contract to procure carriage or freight and insurance on behalf of the Buyer and at Buyer's cost in which event the Seller shall be under no liability for damage in transit or loss or damage to the goods beyond the point at which the Seller contracts to deliver the same. (c) The Seller will not make drop shipments.

9. Inspection and Rejection.

(a) The following provisions shall apply in relation to all deliveries of goods: the Seller shall not be held liable for any claims of damage in transit, shortage of delivery or loss of goods, unless in the case of shortage of delivery, a separate notice in writing is given to the carrier concerned and to the Seller within three (3) days of the receipt of the goods, followed by a complete claim in writing within five (5) days of receipt of the goods and in the case of loss of goods, a separate notice in writing is given to the carrier concerned and to the Seller and a complete claim in writing made within thirty (30) days of the date of consignment. The Buyer must inspect the goods on arrival from the carrier; however, where goods are accepted from the carrier concerned without being inspected, the delivery book of the carrier concerned must be signed "not examined". The Seller shall have the right to inspect the goods at the Buyer's premises in respect to any such claims made by the Buyer and the Buyer shall retain such goods until the Seller has inspected such goods or until the Seller has notified the Buyer that the Seller does not wish to inspect such goods. Any breach of these conditions in this provision shall serve as a waiver to any claim brought by the buyer. (b) Without prejudice to the Seller's other rights, should the Buyer fail for any reason to send the Seller forwarding instructions within ninety (90) days after the date of the Seller's notification that the goods are ready for dispatch or to accept delivery of the goods, the Seller shall be entitled at the Buyer's risk and expense to store the goods and/or to procure or effect storage of the goods elsewhere. Goods so stored shall be paid for as if they had been dispatched and/or accepted.

10. Test and Performance.

(a) The Seller's goods are, where practicable, submitted to the Seller's standard test before delivery. If special tests are required, these shall be made at the Seller's premises unless otherwise agreed, and will be subject to an extra charge. (b) The Seller accepts no liability for failure to attain any performance figures quoted by the Seller unless the Seller specifically has guaranteed them with an agreed sum as liquidation damages and the Buyer has suffered actual loss by reason of the failure to attain the figures quoted. (c) Any particulars of weights and measurements, power and consumption, power output or performance relating to the goods and like matters furnished by the Seller to the Buyer in the Seller's catalogues, literature or otherwise, are approximate and are intended only to present a general idea of the goods to be supplied and unless previously agreed specifically in writing shall not form part of the Agreement.

11. Buyer's Property.

Any designs, tools, patterns, materials, drawings, confidential information or equipment furnished to the Seller by the Buyer, or any other items which become the Buyer's property, may be considered obsolete and may be destroyed by the Seller after two (2) consecutive years have elapsed without the Buyer placing an order for the items which are manufactured using such property. The Seller shall not be responsible for any loss or damage to such property while it is in the Seller's possession or control.

12. Taxes.

Unless otherwise indicated, all prices and charges are exclusive of excise, sales, use, property, occupational or like taxes which may be imposed by any taxing authority upon the manufacture, sale or delivery of the items sold hereunder. If any such taxes must be paid by the Seller, or if the Seller is liable for the collection of such tax, the amount thereof shall be in addition to the amounts for the item sold. The Buyer agrees to pay all such taxes or to reimburse the Seller therefore upon receipt of its invoice. If the Buyer claims exemption from any sales, use or other tax imposed by any taxing authority, the Buyer shall promptly indemnify and hold the Seller harmless from and against any such tax, as well as any interest or penalties thereon which may be assessed if the items are held to be taxable.

13. Warranty.

EXCEPT AS EXPRESSLY WARRANTED IN WRITING BY THE SELLER, THE GOODS SOLD BY THE SELLER ARE PURCHASED BY THE BUYER "AS IS." THE SELLER DOES NOT WARRANT THAT THE GOODS ARE OF MERCHANTABILITY QUALITY OR THAT THEY CAN BE USED FOR ANY PARTICULAR PURPOSE. EXCEPT AS EXPRESSLY WARRANTED IN WRITING BY THE SELLER, THE SELLER MAKES NO REPRESENTATION OR WARRANTY OF ANY KIND WITH RESPECT TO THE PRODUCTS.

(a) The Seller warrants that the items sold hereunder shall be free from defects in material or workmanship at the time of shipment by the Seller. The Seller warrants that if within 12 months of delivery of the goods to the Buyer the Buyer returns immediately to the Seller's premises any of the said goods which the Buyer believes to be defective, carrier paid, properly packed and clearly marked with the Buyer's full name and address and any other information such as serial numbers which may be necessary to enable the goods to be identified, together with a complete description of the alleged defect, they will be repaired or new goods will be supplied in exchange and the goods so repaired or such new goods will be delivered to the Buyer free of charge at the Seller's premises; provided, however, that the foregoing warranty shall be applicable only if upon demand by the Seller, the Buyer proves to the Seller's satisfaction: (i) that the defect was due solely to defective workmanship; (ii) that no alterations or repairs have been made to the goods except with the Seller's written consent; (iii) that the defect was not caused by any act of the Buyer or its agents; and (iv) that the defect was not caused by any matter beyond the reasonable control of the Seller, including, without limitation, accident or normal wear and tear. (b) THIS WARRANTY DOES NOT APPLY UNLESS THE SELLER'S PRODUCTS ARE: (I) USED IN DOMESTIC PLUMBING APPLICATIONS; (II) INSTALLED BY A LICENSED CONTRACTOR, PLUMBER OR QUALIFIED EQUIPMENT INSTALLATION PROFESSIONAL; AND (III) INSTALLED AND OPERATED IN ACCORDANCE WITH PUBLISHED HYDROFIT / HYDRONIX WATER TECHNOLOGY SPECIFICATIONS. (c) All costs and expenses, including freight charges, customs duties, and insurance incurred in returning the goods to the Seller's premises in accordance with this provision shall be paid by the Buyer. The benefit of this warranty shall not be assignable by the Buyer. (d) THIS WARRANTY DOES NOT EXTEND TO ANY GOODS NOT MANUFACTURED BY THE SELLER EVEN THOUGH SUPPLIED BY THE SELLER NOR DOES IT EXTEND TO ANY SECOND-HAND OR RECONDITIONED GOODS NOR DOES IT EXTEND TO COMPONENTS MANUFACTURED BY THE SELLER BUT INSTALLED, ATTACHED OR WELDED BY THE BUYER OR HIS CUSTOMER ON EQUIPMENT NOT MANUFACTURED BY THE SELLER. GOODS NOT MANUFACTURED BY THE SELLER CARRY ONLY THE WARRANTY (IF ANY) OF THEIR MAKERS AND THE BUYER IS ENTITLED TO THE BENEFIT THEREOF ONLY SO FAR AS THE SELLER HAS THE POWER TO TRANSFER IT. (E) THIS WARRANTY COMPRISES THE SOLE AND ENTIRE WARRANTY PERTAINING TO ITEMS PROVIDED HEREUNDER; THE SELLER MAKES NO OTHER WARRANTY, GUARANTEE, OR REPRESENTATION OF ANY KIND WHATSOEVER. ALL OTHER WARRANTIES, INCLUDING BUT NOT LIMITED TO MERCHANTABILITY AND FITNESS FOR PURPOSE, WHETHER EXPRESSED OR IMPLIED, OR ARISING BY OPERATION OF LAW, TRADE USAGE, OR COURSE OF DEALING, ARE HEREBY DISCLAIMED. (F) NOTWITHSTANDING THE FOREGOING, THERE ARE NO WARRANTIES WHATSOEVER ON ITEMS BUILT OR ACQUIRED WHOLLY OR PARTIALLY TO THE BUYER'S DESIGNS OR SPECIFICATIONS.

14. Limited Remedy.

THE SELLER'S LIABILITY ARISING FROM OR IN ANY WAY CONNECTED WITH THE ITEMS SOLD OR THIS AGREEMENT SHALL BE LIMITED EXCLUSIVELY TO REPAIR OR REPLACEMENT OF THE ITEMS SOLD. IN NO EVENT SHALL THE SELLER BE LIABLE TO THE BUYER OR ANY THIRD PARTY FOR ANY INCIDENTAL, CONSEQUENTIAL OR SPECIAL DAMAGES OF ANY KIND OR NATURE WHATSOEVER, INCLUDING BUT NOT LIMITED TO LOST PROFITS ARISING FROM OR IN ANY WAY CONNECTED WITH THIS AGREEMENT OR ANY ITEMS SOLD, WHETHER ALLEGED TO ARISE FROM BREACH OF CONTRACT, EXPRESS OR IMPLIED WARRANTY, OR IN TORT, INCLUDING WITHOUT LIMITATION, NEGLIGENCE, FAILURE TO WARN OR STRICT LIABILITY. IN NO EVENT SHALL THE SELLER BE LIABLE TO THE BUYER OR ANY OTHER ENTITY FOR MORE THAN THE INVOICE PRICE RECEIVED BY THE SELLER FOR ANY NON-CONFORMING PRODUCTS. THE SELLER SHALL NOT BE LIABLE TO THE BUYER OR ANY OTHER ENTITY FOR PERSONAL INJURY, PROPERTY DAMAGE, OR ANY DIRECT, INDIRECT, SPECIAL, INCIDENTAL, CONSEQUENTIAL, PUNITIVE, EXEMPLARY, SPECIAL, OR OTHER DAMAGES OF ANY KIND, INCLUDING WITHOUT LIMITATION THE COST OF PROCUREMENT OF SUBSTITUTE GOODS, THE LOSS OF PROFITS, PRODUCTS, OR PRODUCTION, OR THE INTERRUPTION OF BUSINESS, HOWEVER CAUSED. THE SELLER SHALL NOT BE LIABLE TO THE BUYER OR ANY OTHER ENTITY ON ANY THEORY OF LIABILITY INCLUDING WITHOUT LIMITATION BREACH OF CONTRACT OR EXPRESS OR IMPLIED WARRANTY, TORT, NEGLIGENCE, FAILURE TO WARN, OR STRICT LIABILITY, AND WHETHER OR NOT THE SELLER HAS BEEN ADVISED OF THE POSSIBILITY OF SUCH DAMAGES. THE ESSENTIAL PURPOSE OF THIS PROVISION IS TO LIMIT THE LIABILITY OF THE SELLER ARISING OUT OF THE SALE OF PRODUCTS TO THE BUYER WHETHER FOR BREACH OF CONTRACT, NEGLIGENCE, OR ANY OTHER THEORY OF LIABILITY. THESE LIMITATIONS SHALL APPLY NOTWITHSTANDING ANY FAILURE OF ESSENTIAL PURPOSE OF ANY LIMITED REMEDY AND NOTWITHSTANDING THE PROVISIONS OF ANY OTHER AGREEMENT BETWEEN THE SELLER AND THE BUYER.

15. Indemnity for Infringement of Intellectual Property Rights.

(a) The Buyer shall defend and indemnify the Seller against all actions, claims, demands, penalties and costs by third parties in tort, or for infringement, or alleged infringement, of patents, trademarks, copyrights, trade dress, trade secret or other rights of any third party resulting from the goods manufactured in accordance with the Buyer's specifications or based on any information provided by the Buyer. The Buyer will defend any action against the Seller for title, patent, trademark, copyright infringement, or other claimed by a third party at the Buyer's sole cost and expense. (b) The Seller shall have no liability for infringement of any patents, trademarks, copyrights, trade dress, trade secrets or similar rights except as provided in this provision. The Seller will defend and indemnify the Buyer against allegations of infringement of patents, trademarks, copyrights, trade dress and trade secrets ("Intellectual Property Rights"). The Seller will defend at its expense and will pay the cost of any settlement or damages awarded in an action brought against the Buyer based on an allegation that an item sold pursuant to this contract infringes the Intellectual Property Rights of a third party. The Seller's obligation to defend and indemnify the Buyer is contingent on the Buyer notifying the Seller within 10 days after sole control over the defense of any allegations or actions, including all negotiations for settlement or compromise. If an item sold hereunder is subject to a claim that it infringes the Intellectual Property Rights of a third party, the Seller may, at its sole expense and option, procure for the Buyer the right to continue using said item, replace or modify said item so as to make it non-infringing, or offer to accept return of said item and return the purchase price less a reasonable allowance for depreciation. Notwithstanding the foregoing, the Seller shall have no liability for claims of infringement based on information provided by Buyer, or directed to items delivered hereunder for which the designs are specified in combination or use in a system of any item sold hereunder. The foregoing in this provision shall constitute the Seller's sole and exclusive liability and the Buyer's sole and exclusive remedy for infringement of Intellectual Property Rights.

16. Lien.

In addition to any right of lien to which the Seller may by law be entitled, the Seller shall have a general lien on all goods of the Buyer in the Seller's possession (although such goods or some of them may have been paid for) for the unpaid price of any other goods sold and delivered to the Buyer by the Seller under the same or other contracts.

17. Waiver.

The Seller's rights shall not be affected or restricted by any indulgence or forbearance granted to the Buyer. No waiver by the Seller of any breach shall operate as a waiver of any later breach.

18. Force Majeure.

The Seller shall be excused from performing any of its obligations under this Agreement which are prevented or delayed by any occurrence not within the reasonable control of the Seller, including but not limited to, accidents, acts of God, destruction or damage to the goods or the Seller's manufacturing plant, delays or failures in delivery of carriers or suppliers, shortages of materials, strikes or other labor matters, floods, earthquakes, fire, riots, explosions, or any regulations, rules, ordinances or orders of any governmental authority, federal, state or local, whether such cause exists at the date of the order or not.

19. Buyer's Representation of Solvency.

The Buyer hereby represents that as of the signing of this Agreement it was not insolvent within the meaning of the Uniform Commercial Code or any Bankruptcy Laws.

20. Assignment and Delegation.

The rights and obligations of the parties under this Agreement may not be assigned or delegated, except on the express written consent of the other party to the assignment or delegation.

21. Integration.

The rights and obligations of the parties and the terms and conditions set forth herein, together with any amendments, modifications and any different terms and conditions expressly accepted by the Seller in writing, shall constitute a complete and exclusive statement of the terms of this Agreement. This Agreement supersedes not only all prior agreements, but also oral agreements made contemporaneously with the execution of this Agreement. All such materials may not be used to supplement, explain, or contradict the terms of this Agreement.

22. Severability.

If any of these conditions or any part thereof purports to exclude or restrict or limit any liability and such exclusion or restriction or limitation is prohibited or rendered void or unenforceable by any legislation to which it is subject, or is itself prohibited or rendered void or unenforceable by any legislation to which it is subject, then the exclusion, restriction or limitation on the condition or part thereof in question shall be so prohibited or rendered void or unenforceable and the validity or enforceability of any other part of these provisions shall not thereby be affected.

23. Governing Law/Limitation on Actions.

The terms, conditions, rights, and obligations under this Agreement shall be construed under the laws of the State of California, without regard to principles of conflicts of laws. No actions arising out of the sale of the items sold hereunder or this Agreement may be brought by the Buyer more than two (2) years after such cause of action accrues.

